

**Dometic**  
**SERVICE**

United States

SERVICE OFFICE

DOMETIC SALES CORP.  
509 South Poplar  
LaGrange, N. 46761

# REFRIGERATOR MODEL RM 2192

## For Recreational Vehicle Installation

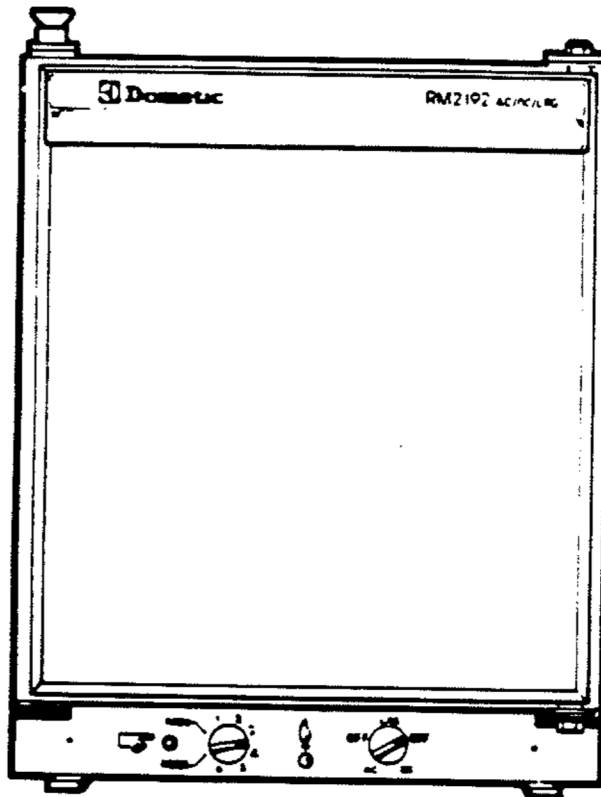

3-Way Operation by 110V AC, 12V DC or LP Gas  
(with direct vent sealed combustion system and electronic ignition)

## INSTALLATION INSTRUCTIONS

REFRIGERATOR

# MODEL RM 2192

Product No. 9268311

### FOR YOUR SAFETY

If you smell gas:

1. Open Windows.
2. Don't touch electrical switches.
3. Extinguish any open flames.
4. Immediately call your gas supplier.

### FOR YOUR SAFETY

Do not store or use gasoline or other flammable vapors and liquids in the vicinity of this or any other appliance.

Form No. 191442.001  
7/86

PSC #312

### 3. DOOR HANG

If required, the door hinge pins can be changed to the opposite side to reverse the door hang. Do this as follows:

1. Holding the small nut with a suitable wrench, unscrew the upper hinge pin. Keep the hinge pin and nut safely for re-use.
2. Pull the door forward at the top to clear the upper hinge brackets, then lift the door away from the bottom hinge.
3. Carefully place the refrigerator on one of its sides then unscrew the lower hinge pin and transfer it, together with its nut, to the front of the elongated hole in the hinge bracket on the opposite side. Stand the refrigerator upright.
4. With the travel catch in the open (upper) position, press forward the travel catch assembly to remove it from the hinge blade and fit it to the hinge blade on the opposite side.
5. Refit the door, engaging its lower hinge bushing over the lower hinge pin before positioning the top of the door and refitting the upper hinge pin and nut.
6. Open and close the door several times, checking to see that the magnetic gasket seals properly against the front frame of the refrigerator cabinet all the way round. If necessary, the seal can be adjusted by loosening the upper and lower hinge pins and repositioning them in the elongated holes in the brackets. When correctly positioned, tighten the hinge pins while holding the nuts with a wrench.

### 4. INSTALLATION

#### GENERAL REQUIREMENTS

The installation of the refrigerator must comply with the following American National Standards, as applicable:

1. Local codes, or, in the absence of local codes, the National Fuel Gas Code, ANSI Z223.1 1980.
2. Manufactured Home Construction and Safety Standard, Title 24 CFR, Part 32-80
3. Local codes, or, in the absence of local codes, the Standard for Recreational Vehicles, ANSI/NFPA No. 501C-1977.

The refrigerator must be installed on a firm base and must be level in relation to the vehicle so that when the vehicle is level, the refrigerator is level.

The appliance must not be installed directly on carpeting. Carpeting must be protected by a metal or wood panel beneath the appliance which extends at least the full width of the appliance.

#### DIMENSIONS OF REFRIGERATOR

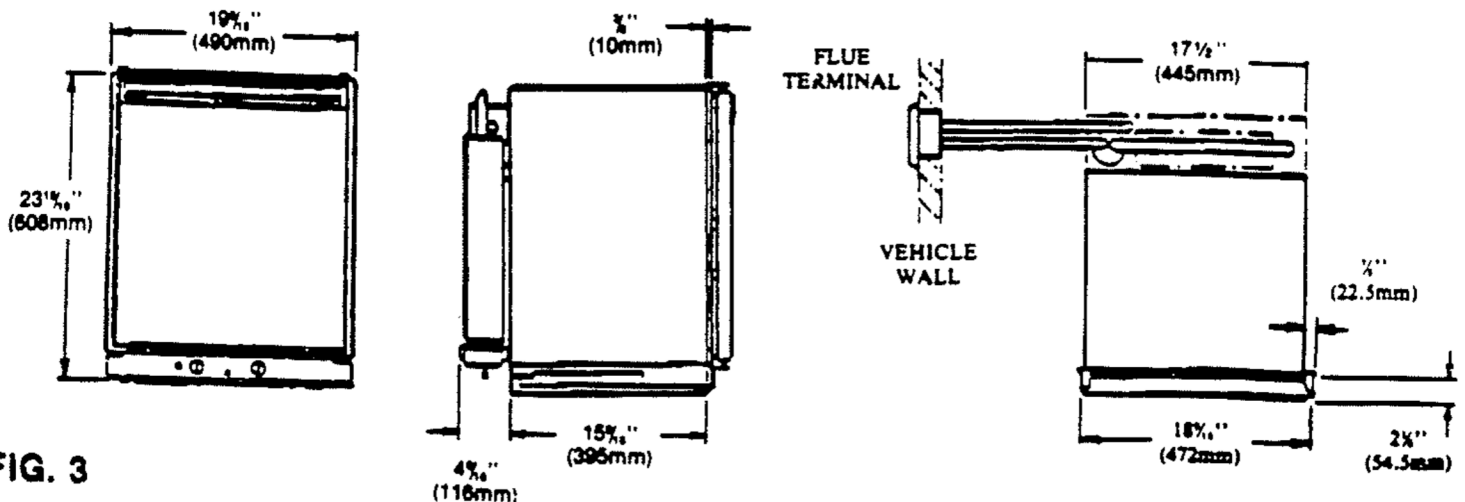

FIG. 3

The overall dimensions of the refrigerator are given in Fig. 3, and the dimensions of the recess to house it are given in Fig. 4.

The following minimum clearances must be allowed at the back and over the top for air circulation over the cooling unit:

Clearance from rear edge of outer casing of refrigerator - 4 inches; clearance over top of unit condenser fins - 1 1/4 inches. This is the minimum height which can be allowed over the condenser fins. Whenever possible, this height should be increased by up to 11 inches; the more ventilation you provide, the better the performance you can expect from the refrigerator.

When installed, the refrigerator must be firmly secured by screws passing through the two holes provided in each side of the front frame of the refrigerator, into the front edges of the recess.

#### The Recess

Details of the recess to house the refrigerator are given in Fig. 4. The internal dimensions of the recess are as follows:

Height = 23 3/8" (608mm)  
 Width = 17 1/2" (445mm)  
 Depth = 21 1/4" (537mm)

These measurements allow clearances for inserting and withdrawing the refrigerator. (When in place, the side trims at the front of the refrigerator will overlap the front edges of the recess).

Make sure that the materials and construction of the recess will be strong enough to hold the refrigerator firmly in place bearing in mind that the vehicle is likely to be traveling at times over rough ground.

#### The Ventilators

Two ventilators are supplied with the refrigerator. These have been certified for use with the refrigerator and contain the proper size openings for the flow of air required. These ventilators must be used and must not be modified in any way.

One of the ventilators must be fitted at the top of the recess, either at the rear as illustrated in Fig. 4, or, if preferred, horizontally in the top surface so that it will be directly over the cooling unit at the back of the refrigerator (see Fig. 2).

**CAUTION:** Do not make the opening in the outer wall larger than is required to just give clearance for the casting (1) to pass through, particularly near the smaller end, otherwise the outer plates (4 and 6) of the flue terminal may not cover the opening completely.

Depending on the type of construction of the vehicle (for example, if there is an open air gap between the outer and inner skin); it would be advisable to line the edges of the openings with a strip of metal or other suitable material to bridge the gap and seal the cavity between the two skins (not necessary with sandwich construction).

Do not fit the flue terminal or flexible tubes to the vehicle or the refrigerator yet - this is to be done at a later stage (Item 8).

## 5. GAS PRESSURE AND BURNER JET

The burner is fitted with a size F jet which is suitable for use on Propane gas at a supply pressure of 11" water column.

The gas bottle which you use must be fitted with a 2-stage pressure regulator to reduce the pressure of the gas to 11" water column. The refrigerator must not be connected to a supply without the appropriate pressure regulator being fitted.

## 6. GAS CONNECTION

The supply pipe from the pressure regulator on the gas bottle to gas inlet on the refrigerator should be of copper or of an approved flexible material that is suitable for use with continuously operating LP-gas appliances.

The gas connection on the rear of the refrigerator, to which the supply pipe is to be connected (after the refrigerator has been fitted into the recess), has a male  $\frac{1}{2}$ " 18 U.N.F. thread. This is accessible through the inspection panel referenced in Section 4 under "Inspection Panel". The route of the supply pipe should be considered and any preparatory work carried out before finally securing the refrigerator in the recess and connecting.

After installation, all gas connections must be checked for leaks as described in Item 9.

## 7. ELECTRICAL CONNECTIONS

For electrical operation, the boiler of the cooling unit is fitted with two separate heaters, one for use on 110V AC, the other for 12V DC. Each heater is rated at 95 watts.

If an external electrical source is utilized, the refrigerator, when stalled, must be electrically grounded in accordance with local codes or, in the absence of local codes, the National Electrical Code, ANSI/NFPA No. 70-1991.

### (a) 110 Volts AC

The connection cord for 110V AC supply has a three-prong (grounding) plug for your protection against shock hazards and is intended to be plugged directly into a properly grounded three-prong receptacle. DO NOT cut or remove the grounding prong from this plug.

The cord is 5' 6" long and a grounded three-prong receptacle should be installed in an accessible position within reach of the plug.

### (b) 12 Volts DC

The electric equipment terminal block is located underneath the refrigerator and is protected by a metal cover. Remove the cover by taking out the two screws and the terminal block will then be seen.

The two terminals at the end of the terminal block, marked "12V", are for connecting the refrigerator to the vehicle's 12 V DC supply in making the connection, the following points must be borne in mind:

1. The current drawn by the refrigerator when operating on 12 V DC is 8 amps, therefore the wiring from the supply to the refrigerator must be heavy enough to carry this load without undue voltage drop. The MINIMUM size of wire to be used for the supply and return is 14 A.W.G.
2. Correct polarity must be observed otherwise the electronic igniter will not operate. (See wiring diagram.)
3. Both wires should pass through the entry opening in the terminal block cover, temporarily sealed with a dust cap which must be removed.
4. DO NOT CONNECT LIGHTS OR ANY OTHER ELECTRICAL COMPONENTS TO THE WIRING FROM THE BATTERY TO THE REFRIGERATOR.

### (c) Fuse

Inside the control equipment box in an insulated holder, underneath the refrigerator at the front, is a 10 amp fuse, which is to protect the 12 volt circuit in the event of a short. If the fuse burns out, trace the cause and correct it before fitting a similar type 10 amp fuse and reconnecting.

## 8. INSTALLATION IN THE RECESS

When the recess has been constructed and all other requirements described earlier have been completed or prepared for, the refrigerator can be installed in the recess and the flue components fitted, in the following sequence:

1. Fit the two flexible tubes to the flue terminal casting (1, Fig. 5) in the following manner.

Place the two "O" rings (7 and 8) into the third groove on the outside of the respective tube ends, wet the "O" rings and casting to ease assembly, then push the casting firmly onto the tubes. Slide the locking plate (9) into the grooves between the tubes, close to the casting, and secure it with the M5 x 10 screw (10).

2. From outside the vehicle, feed the free ends of the flexible tubes through the opening in the vehicle wall.
3. Push the refrigerator into the recess and connect the tubes as follows. (Appropriate size openings will have to be made in the side of the recess for the tubes to pass through).

a. **EXHAUST TUBE** (the one with the smaller diameter).  
Push the end of this tube over the CENTRAL tube at the top of the boiler of the cooling unit. Line up the screw holes and secure with the self-tapping screw.

b. **INLET TUBE** (the larger diameter tube).  
Fit the larger end of the rubber sealing sleeve over the end of the flexible inlet tube then push this tube firmly over the top of the air inlet tube which is beside the boiler. (The rubber sleeve must be positioned to seal the joint).

# WIRING DIAGRAM

